

取付金具詳細図 S=1:10

1300SQ

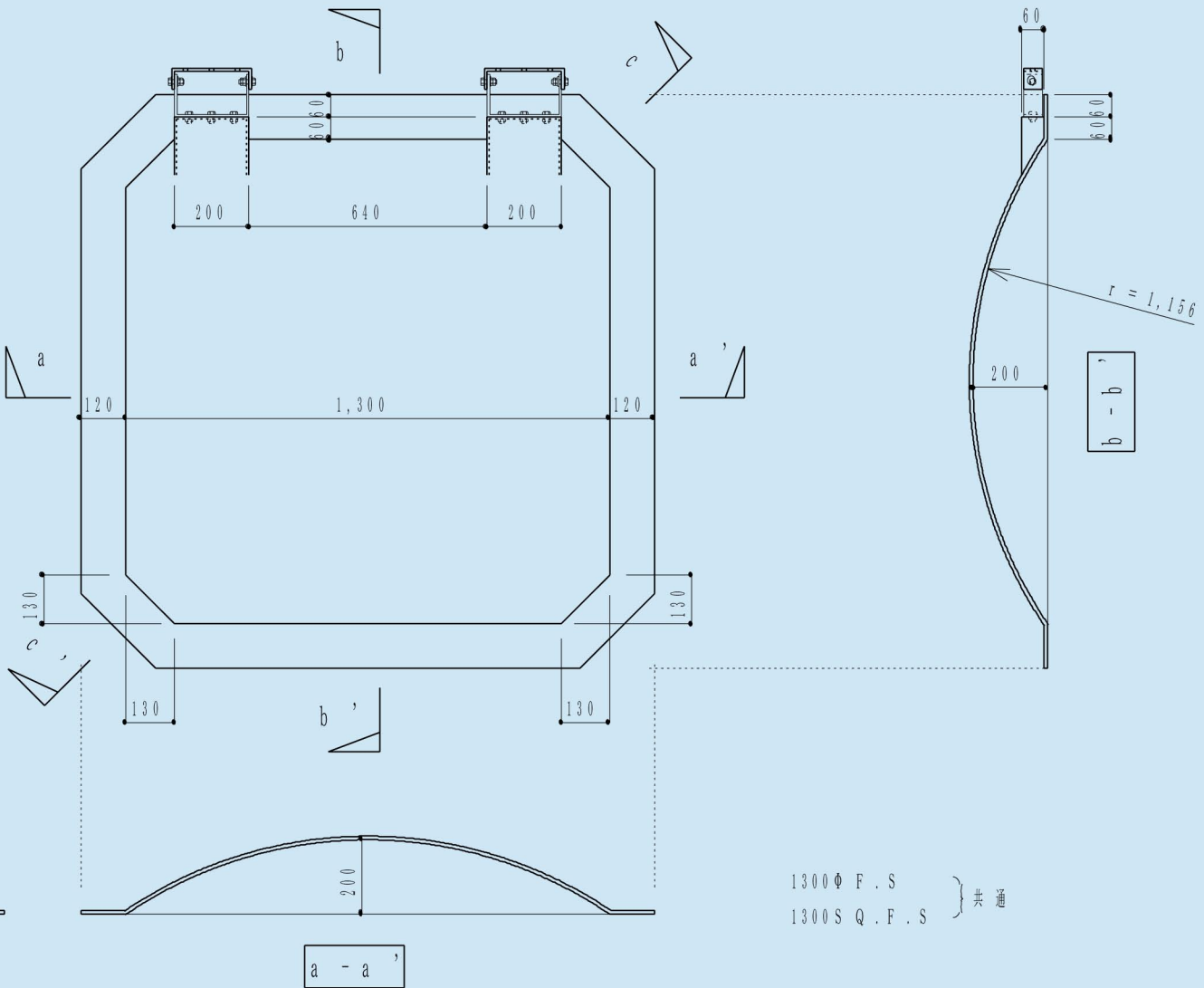

岩手大学工学部共同研究開発

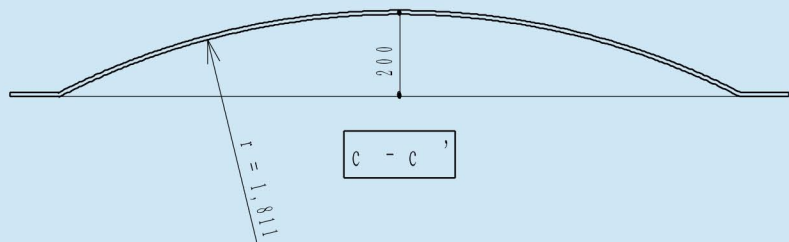

Sunkyo C.

三協化成

実用新案登録第3052095号